

## Electr-O-Fuze™ EF Transition Tee, UL971 Listed

### Product Description

Electr-O-Fuze™ fittings are safe, reliable and a proven electro fusion technology using open wire principles. Electr-O-Fuze™ Transition Tee's are the only fittings used in petroleum industry to also be tested and approved for use with natural gas and low pressure gas, thus providing unparalleled quality and protection. When used in conjunction with Electr-O-Fuze™ pipe and a Electr-O-Fuze™ EF welding machine, it provides a UL971 compliant fuel installation with a 30 year life span.

Electr-O-Fuze™ Transition Tee's are available in sizes 1½" and 2" nominal bore. The transition section is combined on the spigot of the Tee, thus eliminating one of the couplers and a possible leak point. It also offers a reduced overall size of the complete tee and transition combination, for ease of installation, and space saving in the sump.

### Applications

- Service stations
- Marina's
- Fuel Terminals
- Moist and marshy areas
- Refineries
- Harbours
- Airports
- Non-Contaminated and Contaminated sites

### Specifications

- Fitting Type : Matched electro fusion fittings are utilized throughout the pipeline system in order to join the various pieces. Deep sockets and 'safe' low voltage operation (42V), applied through dedicated ancillary equipment ensures maximum joint integrity. Fusion indicators monitor the joint melt pressure, while absolute security of the weld is ensured using the fittings bar code feature in conjunction with the fully automatic Electr-O-Fuze™ EF welding machine. The transition Spigot is threaded both on the inside and outside with NPT thread for flexibility of use and is factory leak tested.
- Electrofusion Machine: Electr-O-Fuze™ EF welding machine with memory, bar code reader, printing and error reporting
- Temperature range : Fittings can be worked with at ambient temperatures between -24°F and 160°F.
- Pipe fusion range : The fittings can be fused to pipe of SDR stages 17.6 to 7.4 in accordance with DIN 8074 (E), ISO 4437, pr EN 1555 and DIN EN 12201 (E).
- Operating pressures : 150 psi maximum
- Test pressure : Primary >60psi <150psi; Secondary 50psi with EF test boots & 5psi with rubber test boots.
- Approved Fuel Types : All Petroleum Products (Motor Vehicle Fuels, High Blend Fuels, Concentrated Fuels, Aviation & Marine Fuels) E85 and Biodiesel

### Installation

Installation, use, and maintenance of all Electr-O-Fuze™ products shall be in accordance with the manufacturer's recommendations, State and County approvals. In event of conflicts, the stricter requirement shall govern. (AEP installation manual available directly from AEP, or at [info@aep-inc.net](mailto:info@aep-inc.net). All operators to be AEP certified on both the fittings and electro fusion machine.

### Certifications/Approvals

- UL 971 approved, File # MH47372
- Institute of Petroleum Cert # BC63/1010/98/001 And cert # BC63/0115/2000/001
- Shell Int. Procurement Cert. Cert # BC63/1010/98/002
- State of Florida EQ 683 and EQ 617 – and Derm Approval
- State of Michigan MUSTR – Rule 9, subsections 280.20 (b)
- New York City Fire Dept. CoA 5117
- DVGW Permit VP 607, with decisions DV-8601AU2248, DV-8606AU2249 and DV-8611AU2250
- Factory Permit DIN EN 10 204-3.1
- State of California CARB, State Fire Marshall Cert # GVRC 005:060:001

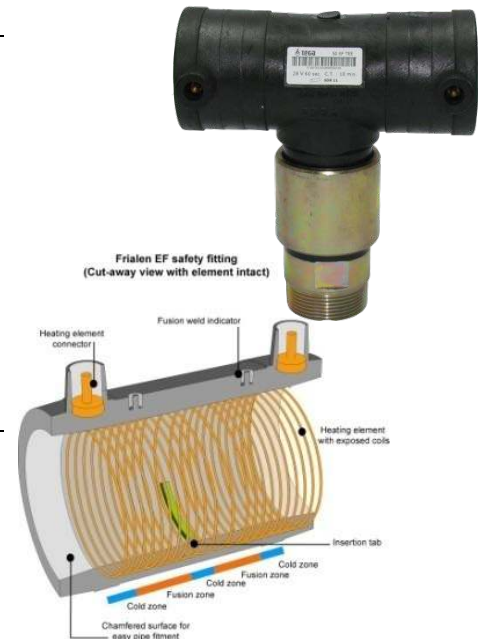

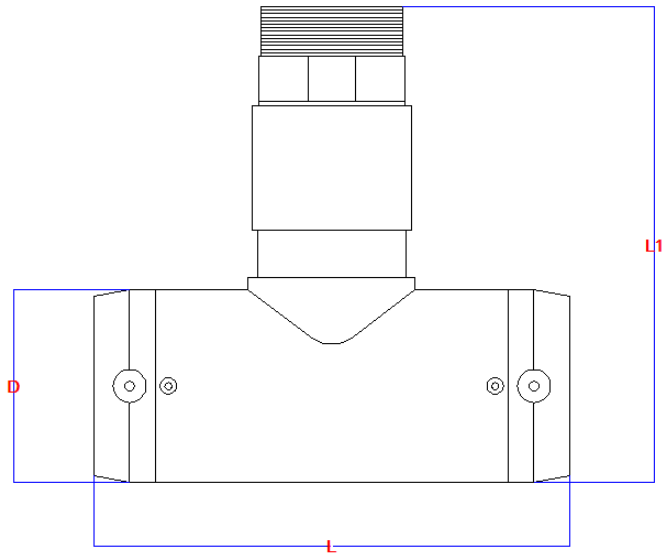

Diam. NB* inches	Diam OD** Metric	Part #	Dim L1		Dim D		Dim L		Weigh Kg/each	Weigh Lbs/each
			mm	In.	mm	In.	mm	In.		
1½"	50	005-050EFTR	181	7.13"	68	2,68	162	6.37"	0.8	1.76
2	63	005-063EFTR	202	7.95"	82	3,23	186	7.32"	1.4	3.08

(\*) Nominal Bore

(\*\*) Outside Diameter